

DISTRIBUTOR INFORMATION:



Factory: Hongqiao Yueqing, Wenzhou, Zhejiang

Overseas Dept.: Room 1102, Building 1, No. 7866 Humin Road,
Minhang Dist., 201102, Shanghai, China

E-mail: sales@viossewing.com

huapu@viossewing.com

info@viossewing.com

Website: www.viossewing.com

GENERAL CATALOGUE

2026



Website



Youtube



Facebook

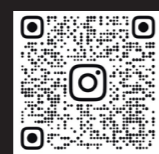

Instagram

Expert on heavy duty sewing & solution supplier

Produce spare parts & control system by ourselves



Company Introduction

VIOS factory was founded in 2012 in Yueqing, Wenzhou, Zhejiang province, specialized in R&D, manufacturing and sales of various industrial sewing machines especially heavy duty, factory is awarded "Zhejiang Provincial Science and Technology Enterprise", "National High-tech Enterprise" and other honorary titles.

VIOS factory covers an area of over 8,000 square meters, integrating R&D, production, and domestic sales, equipped with the world first-class processing equipment, automatic&intelligent&precise machining centers and assembling lines. We produce over 95% spare parts including control system by ourselves. Relying on a strong R&D team, factory has successively obtained patents, software copyrights, and certification certificates more than 30 items.

VIOS has a professional overseas business team, show room and R&D dept., in Shanghai which is located in Lotus square Minhang Dist., VIOS can give partners high-quality, leading technology and sewing solutions, especially for automotive, upholstery, tent, bag, ect., industries.

VIOS brand has four series: 667, 867, 868, and 669, full series have been undergone 3 years of independent R&D, and 5 years market verification, nowadays VIOS has already broken the monopoly of foreign brands in the top lever on heavy duty sewing market. Now VIOS has occupied over 60% domestic market for automotive and upholstery industry customers, such as JUJIN, LEAR, NOBO, MAGNA, CADI-VITE and KUKA, QUANU, DERUCCI, etc.,

01

About us

Company introduction	01
Factory show	02
Certificates and customers	03

02

Product

667 Series	04
867 Series	08
868 Series	12
820 Series	16
669 Series	20

03

Spare parts service

Optional spare parts	24
----------------------	----

Factory show

In intelligence, constant humidity, and stability temperature workshop, each sewing machine would be gone through hundreds of processes for fine polishing and strict testing to ensure its stable performance, durability and reliability



Certificates



- National High-tech Enterprise;
- Zhejiang Province Science and Technology Enterprise;
- Wenzhou Municipal R&D Center;
- Several Invention Patents;
- Several utility model patents and several design patents;
- Several software work patents;
- CE certificate;



Customers



卡迪韦特





VIOS 667 Series flat bed

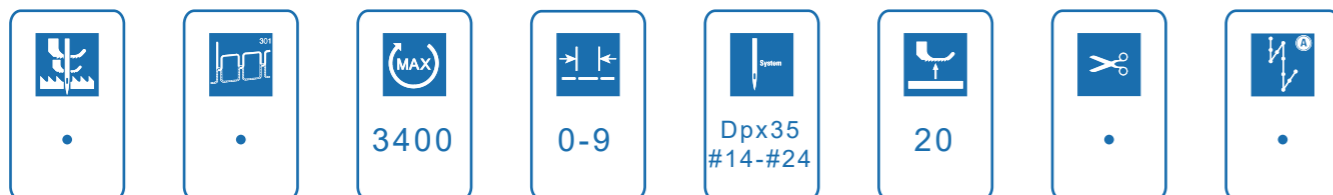

- Max.stitch length 9mm ;
- Thickest thread Nm10/3 ;
- Max sewing speed 3400RPM ;
- Max.presser foot feed stroke up to 9mm;
- LED lighting, Self-developed stable VIOS control system;
- Full functions,including automatic trimmer,auto backtacking,PFL,HP function,Knee presser foot lifter device
- 26mm or 32mm hook,32mm XXL hook for extra 70% bobbin capacity ;
- LED lighting, stable and powerful control system ;
- Air pressure:4.0NL.6Bar ;
- Z-intergrated direct drive ;
- Widely used on all field of medium-heavy duty applications
- Pneumatic presser foot lifter Max.20mm ;
- Large clearance 335*125 mm ;



▪ Compound feeding



▪ Horizontal



▪ Programming buttons

Optional device

667 series widely used on home upholstery, room decoration and technical textiles, etc.

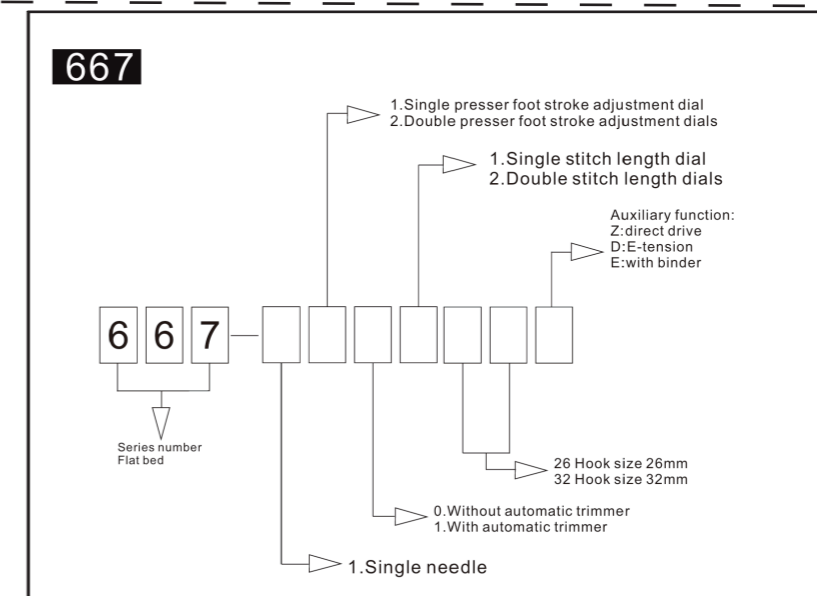
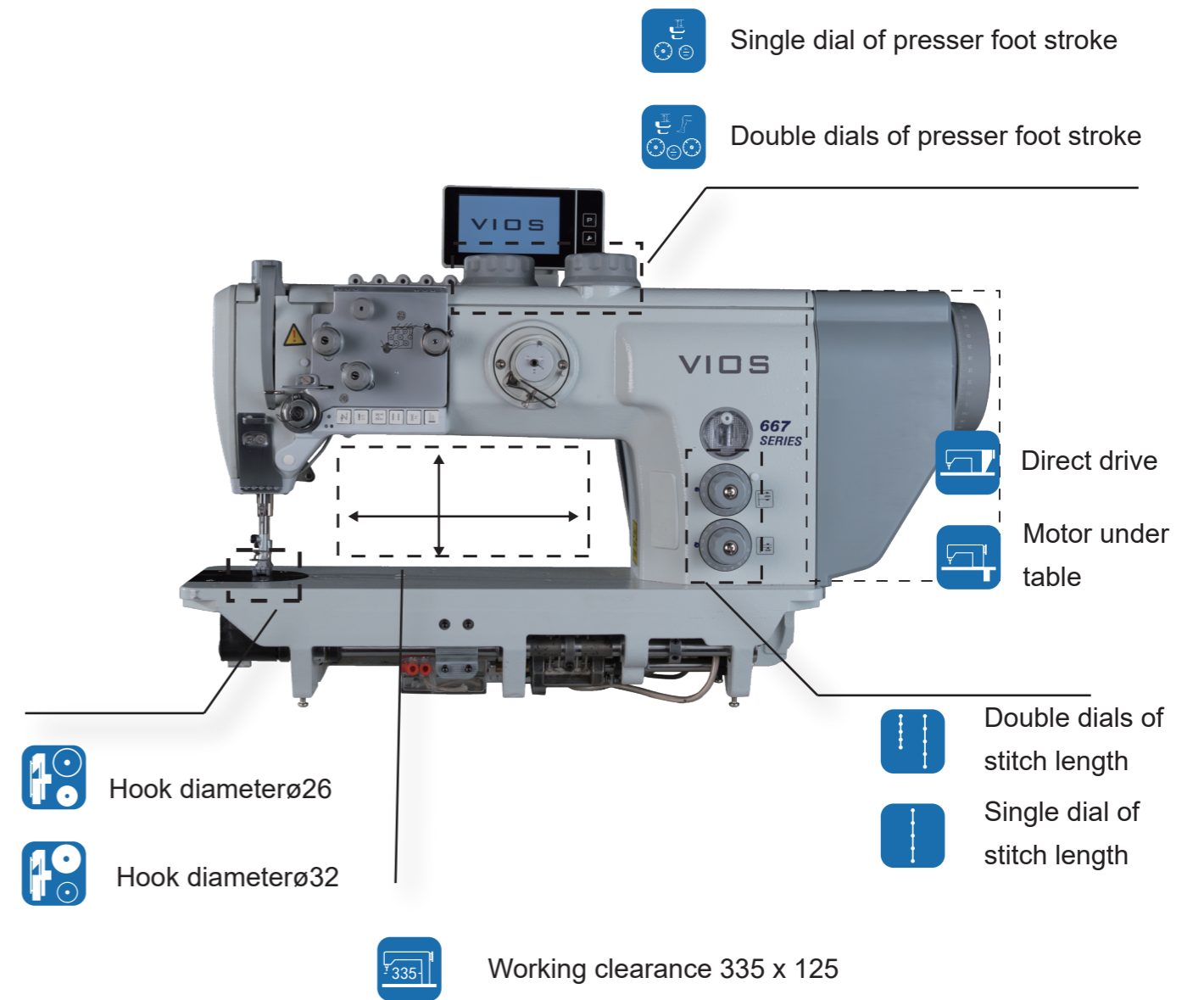



VIOS 867 Series flat bed

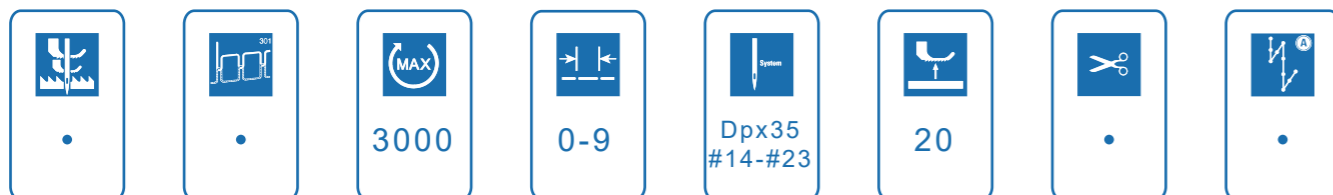

- Stitch length 9mm(Optional 12mm);
- Max sewing speed 3000RPM(1500RPM for 12mm stitch length)
- Press foot stroke up to 9mm;
- 32mm XXL hook for extra 70% bobbin capacity;
- LED lighting, Self-developed stable VIOS control system;
- Pneumatic presser foot lifter Max.20mm
- Full functions,including automatic trimmer,auto backtacking,PFL,HP function,Knee presser foot lifter device;
- Needle gauge for double needles(3-70mm,normally 4mm,6mm,8mm,10mm,12mm);
- C with edge cutter,cutting size:1.2-2.5MM;
- Large clearance 335*125mm,400*125mm and 460*125mm.



▪ Compound feeding



▪ Imported hook



▪ Programming buttons

867 series widely used on automotive, upholstery, tent, etc.



Optional device

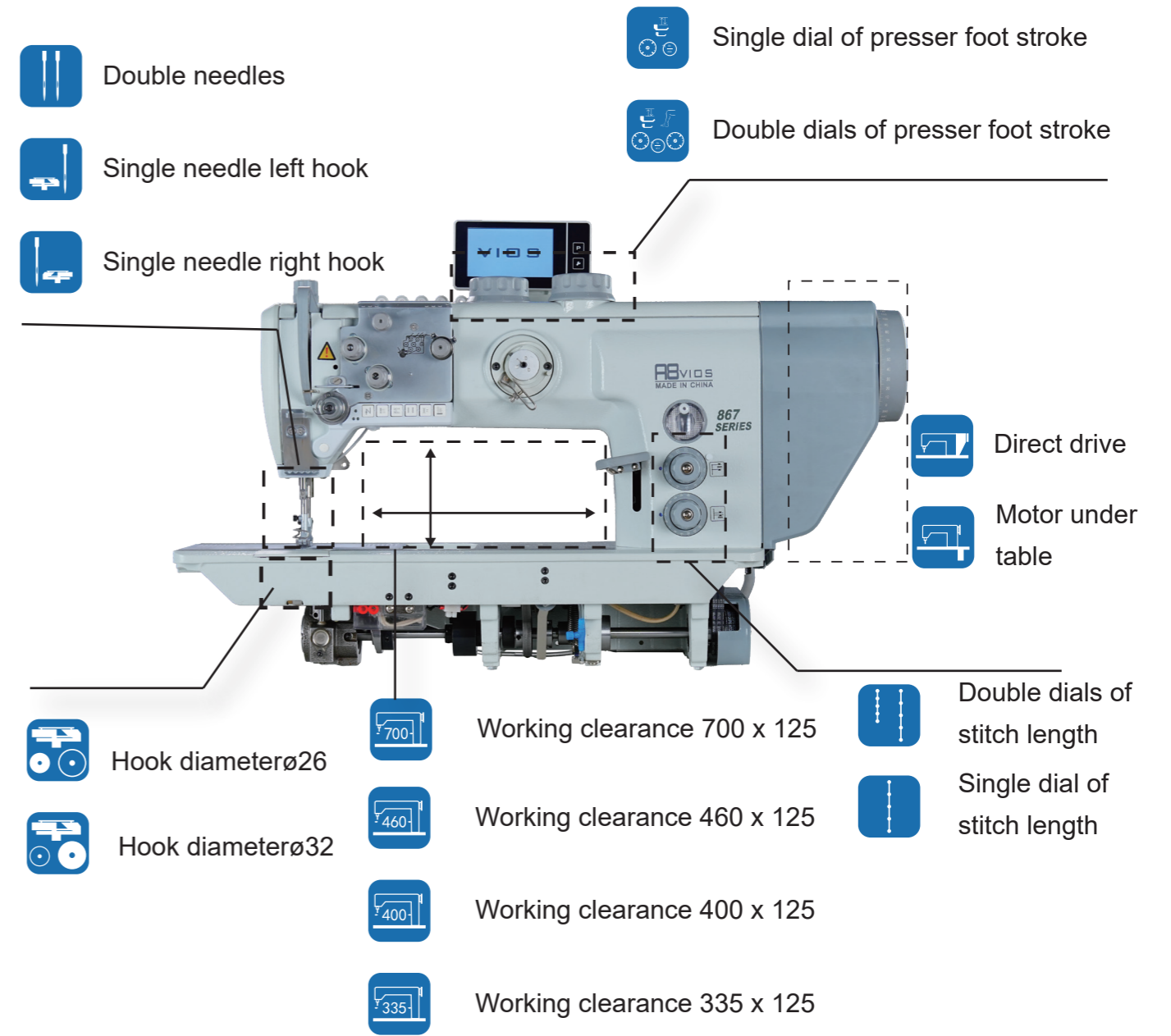

Arm bed type: A



Arm bed type: B

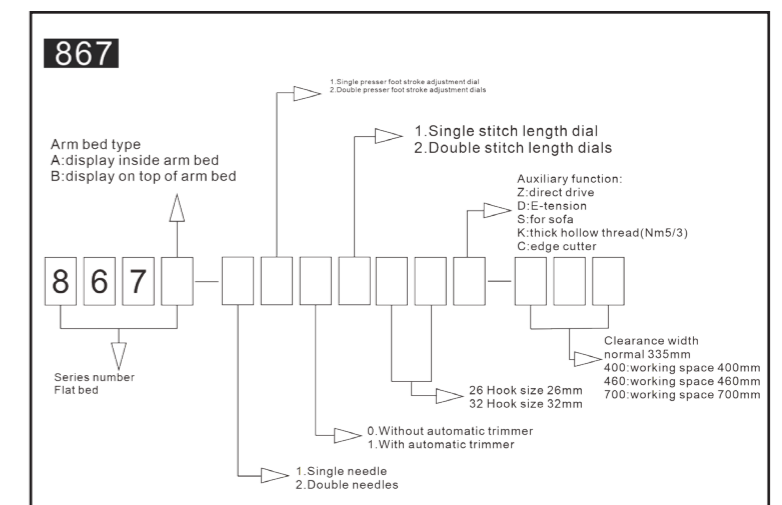
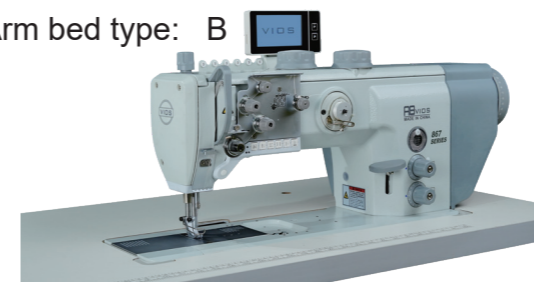



VIOS 868 Series high post

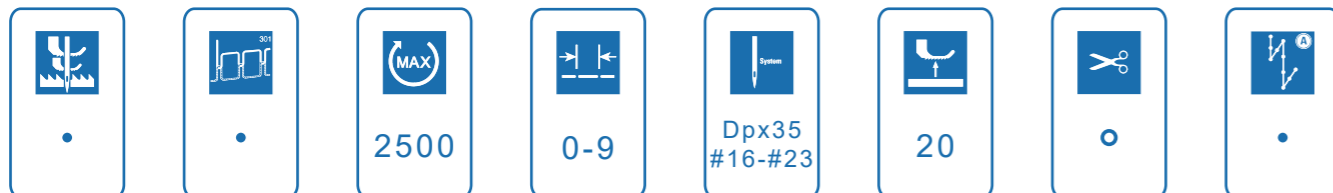

- LED lighting, self-developed VIOS control system;
- Hook 26mm and 32mm;
- Needle gauge for double needles(normal 4mm,6mm,8mm,10mm,12mm);
- Max.presser foot lifter 20mm;
- Max.sewing speed 2500RPM;
- High top feed stroke up to 9mm;
- Wide clearance:335*295mm
- Full functions,including automatic trimmer,auto backtacking and pneumatic presser foot lifter,HP function,Knee presser foot lifter device(depends models);



▪ Compound feeding



▪ Imported hook



▪ Programming buttons

868 series with post bed easy to handle material with complex curves, widely used for decorative seam on car seat headrest, cover, sofa armrest, etc.



Optional device

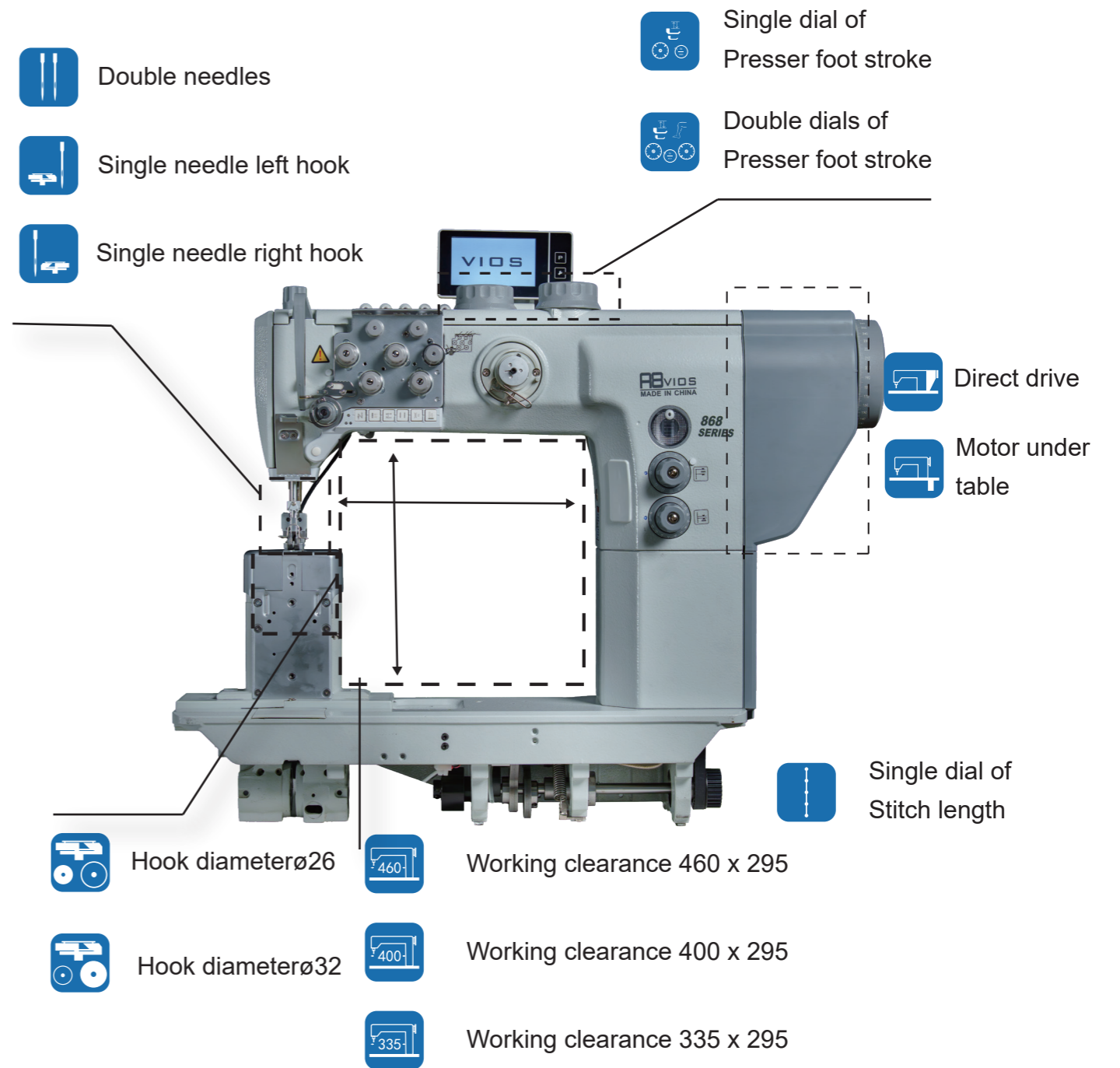

Arm bed type: A



Arm bed type: B

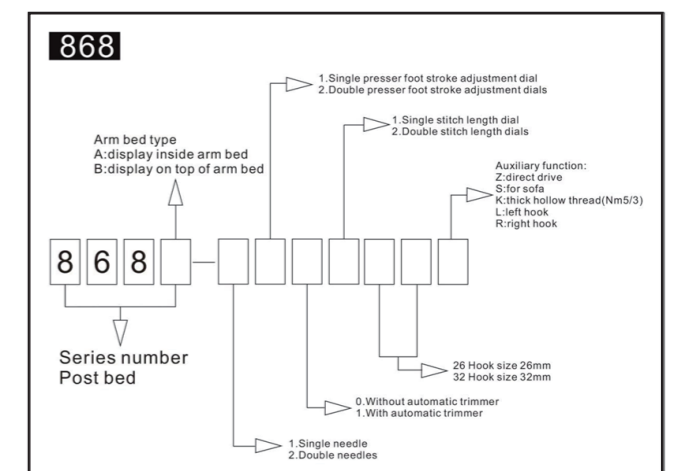
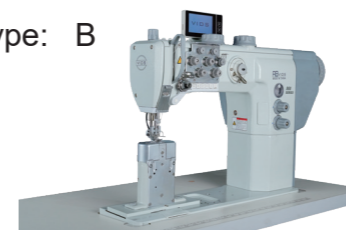



VIOS HM820 Series decorative stitches

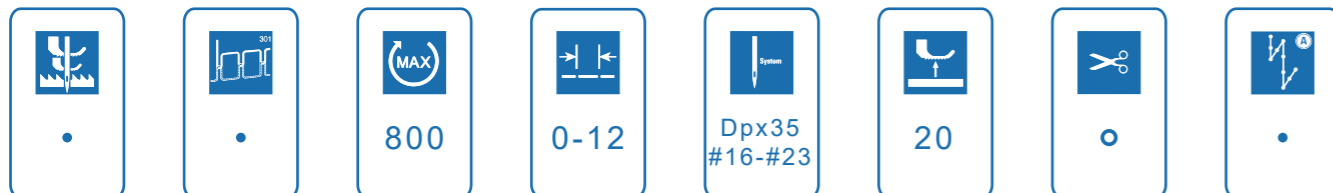

- LED lighting, self-developed VIOS control system;
- Hook 26mm and 32mm;
- Needle gauge for double needles (normal 6mm, 8mm);
- Max. presser foot lifter 20mm;
- Max. sewing speed 800RPM;
- High top feed stroke up to 9mm;
- Full functions, including automatic trimmer, auto backtacking and pneumatic presser foot lifter, HP function, Knee presser foot lifter device (depends on models);
- 200+ standard decorative stitch patterns and 100+ user designed patterns.



▪ Needle bar rotation



▪ Compound feeding



▪ Programming buttons

Optional device

The HM820 is a machine for sewing decorative stitches in home upholstery, but can also be used for leather goods or other materials where triple transport machines are required.

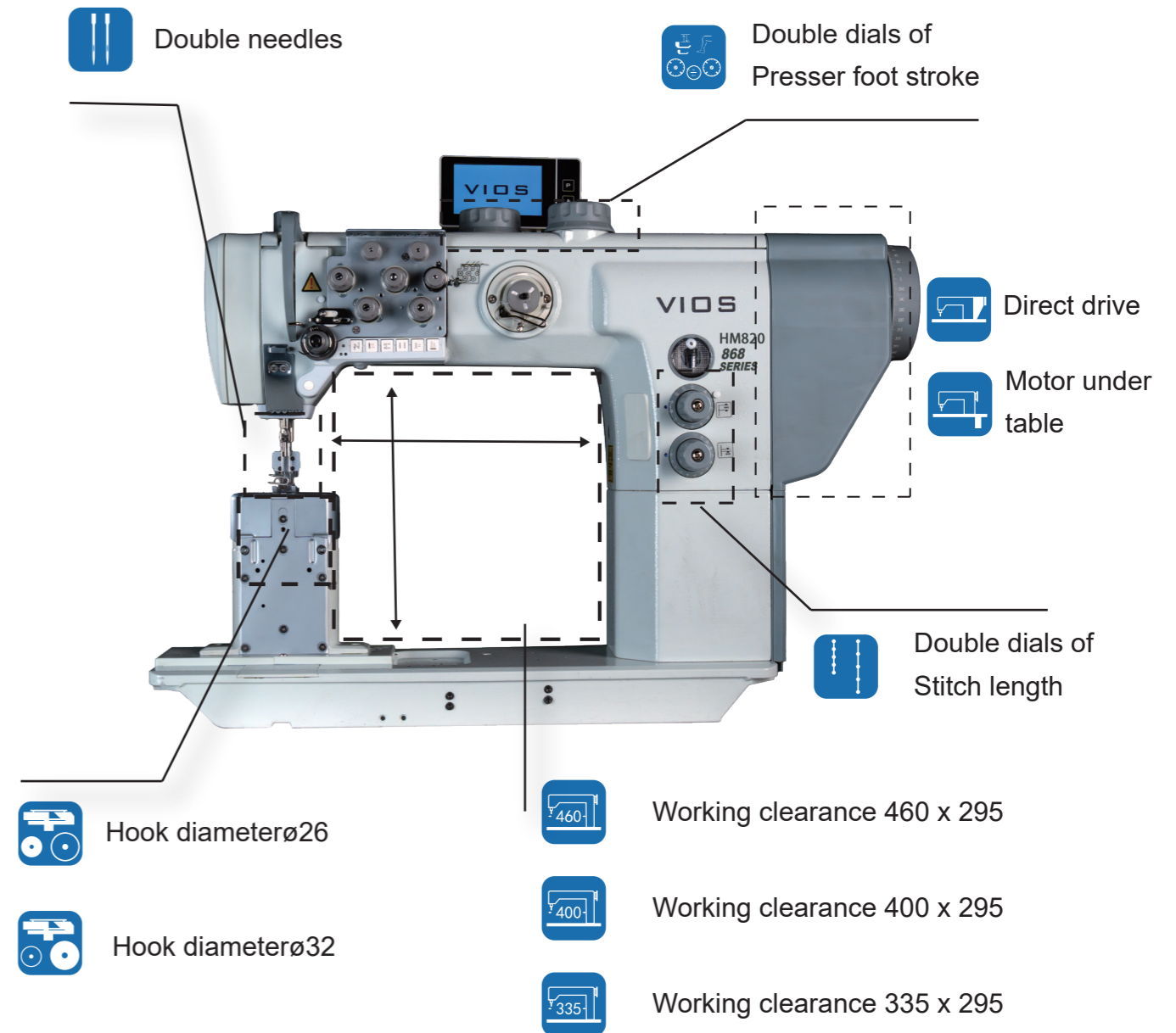

Arm bed type: A



Arm bed type: B

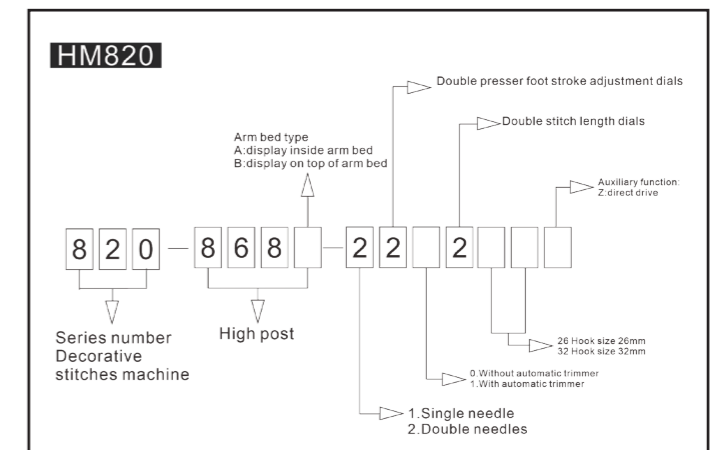
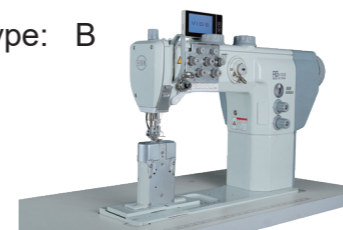



VIOS 669 series cylinder bed

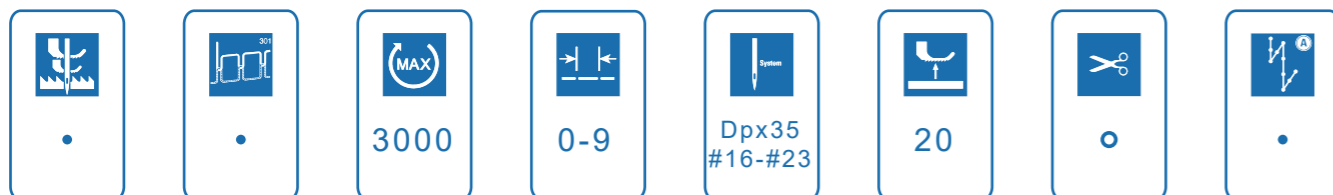

- Max.stitch length 9mm (Optional 12mm);
- Max.sewing speed 3000RPM;
- Max. presser foot stroke up to 9mm;
- LED lighting, Self-developed stable VIOS control system;
- Pneumatic presser foot lifter Max.20mm
- Large clearance 335*125mm.
- Full functions,including automatic trimmer,auto backtacking and pneumatic presser foot lifter,HP function,Knee presser foot lifter device(depends models);



▪ Compound feeding



▪ Imported hook



▪ Programming buttons

669 series slim arm is easy to handle small leather and tubular seams, widely used in women leather bag, car mat, belt, etc



Optional device

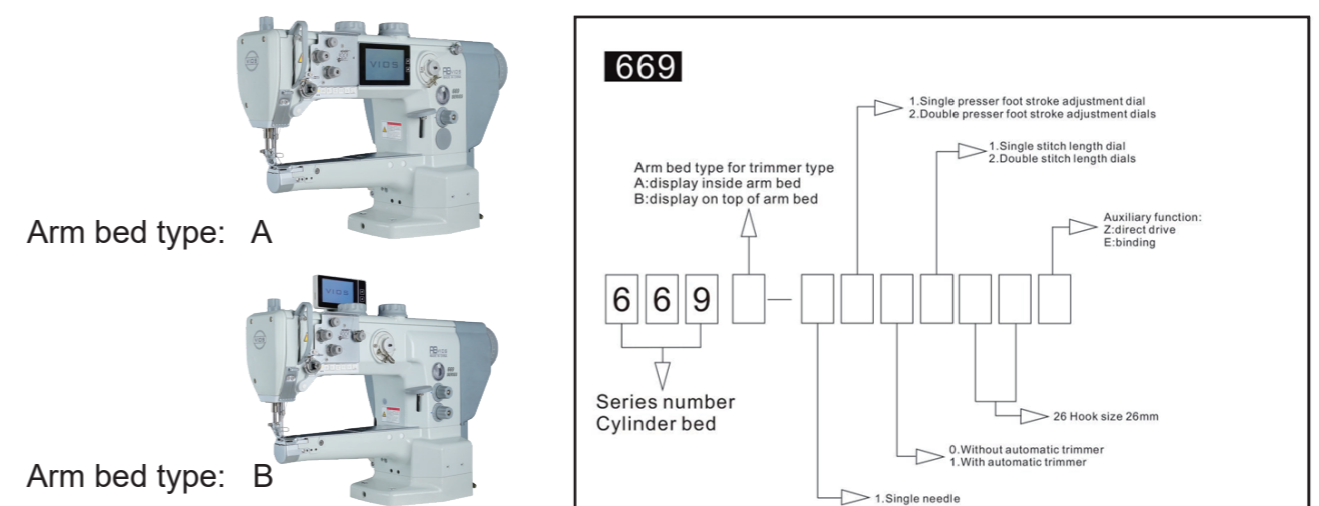
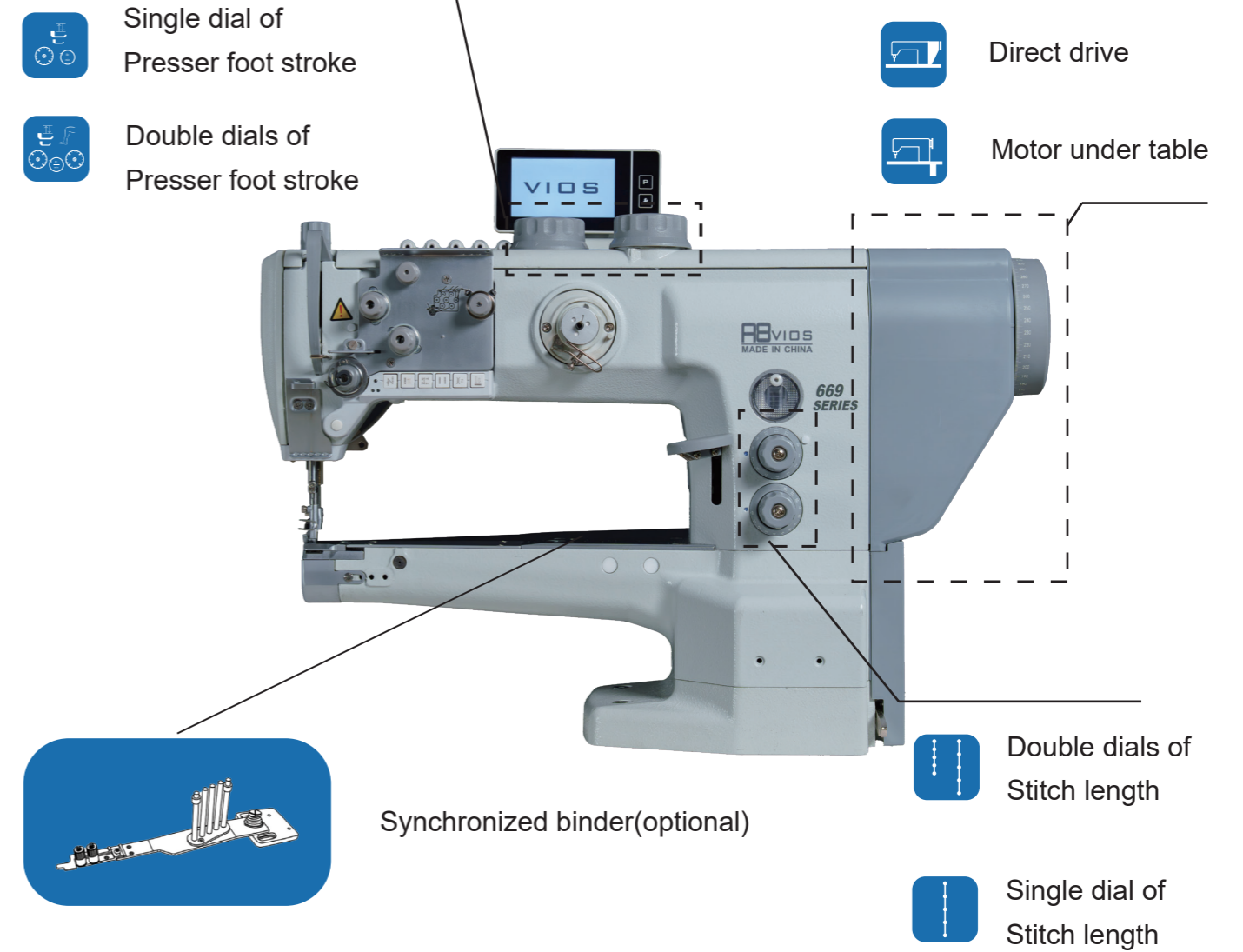

Spare parts service

Details to be found on: www.viossewing.com

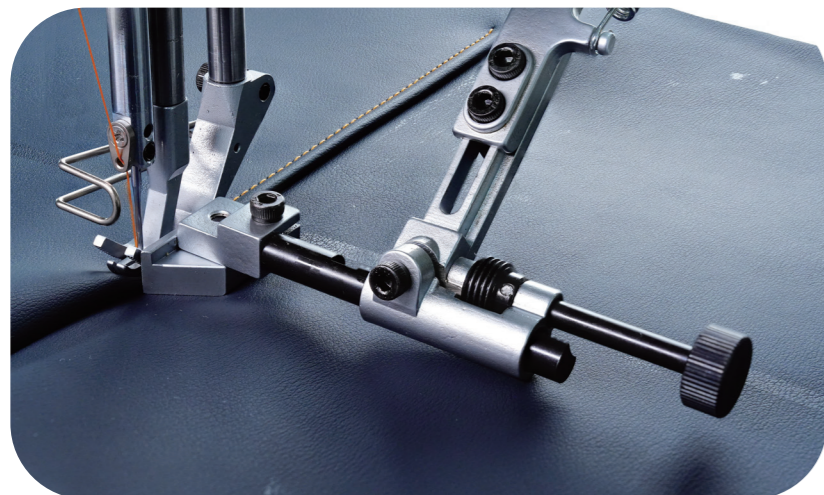

High Quality

Leading Technology

Solution Supplier

